

Equipment

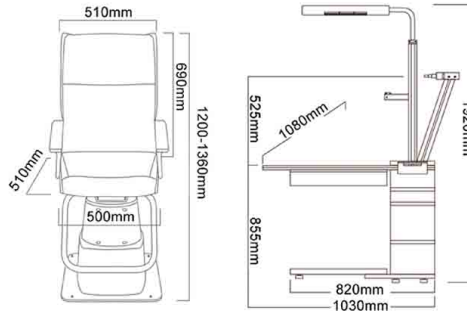

C-180A



FEATURES

FEATURES

Table Size	800x500mm
Drawer Size	540x380mm
Arm Up And Down Range	170mm
Chair Up And Down Range	170mm
Light	20W
Voltage	110V/220(60/50Hz)
Power	120W
Unit Size	880x600x710mm
Weight	60kg

Unit Size	1030x1080x1920mm
Table Size	1030x480x120mm
Drawersize Size	550x340x60mm
Swing Arm Left & Right Swing Distance	500mm
Tabletop Rotation Range	90°
Chair Lifting Height	160mm
Power Of Lamp	20W
Power	120W
Input Voltage	AC110V/220(60/50Hz)
Weight	200kg



电动控制椅升降。
Electric power controlled chair down.

摆臂左右摆动。
The arm can swing left and right.

小台桌可在左右移动。
Small Desktop Can Move Left and Right.

台面可旋转90°。
Tabletop can rotate 90°.

S-600B

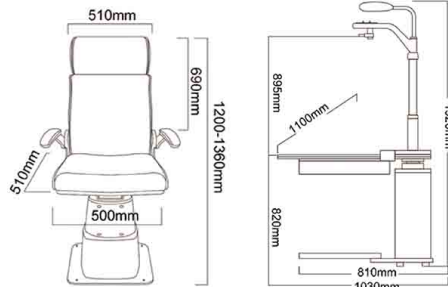

电动升降，可以90°旋转。
Electric power chair 90° rotating.

摆臂可上下升降，90°旋转。
The arm can lift up and down, rotate 90°.

小台桌可在左右移动。
Small desktop can move left and right.

台面可90°旋转，上下升降。
Tabletop can rotate 90°, lift and lower.

FEATURES

Unit Size	1030x1080x1920mm
Table Size	1030x480x120mm
Drawersize Size	550x340x60mm
Swing Arm Left & Right Swing Distance	300mm
Tabletop Rotation Range	90°
Chair Lifting Height	160mm
Power Of Lamp	20W
Power	120W
Input Voltage	AC110V/220(60/50Hz)
Weight	220kg

CS-700B

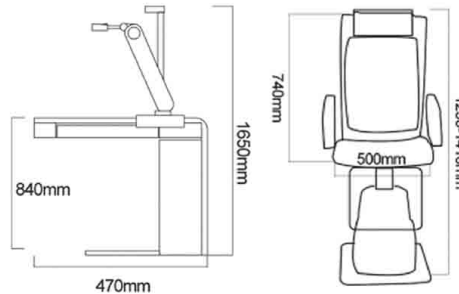

FEATURES

Unit Size	960x1000x1650mm
Table Size	960x470mm
Arm Movable Range	140mm
Chair Up And Down Range	160mm
Tabletop Rotation Range	90°
Drawersize Size	570x380x60mm
Input Voltage	AC110V/220(60/50Hz)
Weight	200kg

镜盒

CASES

4 - 21

清洗液

SPRAY

22 - 24

镜布

MICROFIBER

25 - 31

纸袋

BAGS

32 - 33

设备

EQUIPMENT

35 - 65

设备配件

EQUIPMENT

ACCESSORIES

66 - 94

钳子

PILERS

95 - 102

螺丝

SCREWS

103 - 105

眼镜配件

GLASSES

ACCESSORIES

106 - 121

镜绳

GLASSES

CHAINS

122 - 126

道具

PROPERTY

128 - 137

镜架

FRAME

139 - 146

镜片

LENS

148 - 153

礼品

GIFTS

155 - 157

- 镜盒
CASES
- 4-21
- 清洗液
SPRAY
- 22-24
- 镜布
MICROFIBER
- 25-31
- 纸袋
BAGS
- 32-33
- 设备
EQUIPMENT
- 35-65
- 设备配件
EQUIPMENT
ACCESSORIES
- 66-94
- 钳子
PLIERS
- 95-102
- 螺丝
SCREWS
- 103-105
- 眼镜配件
GLASSES
ACCESSORIES
- 106-121
- 镜绳
GLASSES
CHAINS
- 122-126
- 道具
PROPERTY
- 128-137
- 镜架
FRAME
- 139-146
- 镜片
LENS
- 148-153
- 礼品
GIFTS
- 155-157



PK-100B

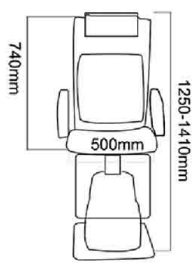

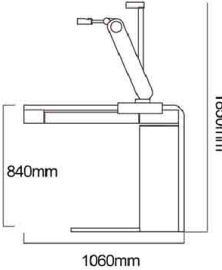

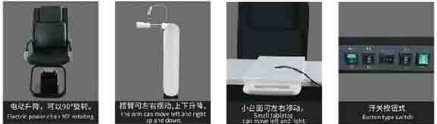

FEATURES

Unit Size	1060×1020×1850mm
Table Size	1060×450mm
Arm Up And Down Range	200mm
Swing Arm Left & Right Swing Distance	450mm
Drawersize Size	570×380×65mm
Chair Up And Down Range	160mm
Tabletop Rotation Range	90°
Input Voltage	AC110V/220(60/50Hz)
Weight	220kg



S-880B

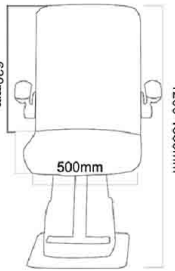

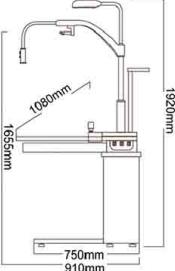



FEATURES

Unit Size	1200×1100×1900mm
Table Size	780×420×100mm
Table Movable Distance	90mm
Arm Up And Down Range	280mm
Chair Up And Down Range	160mm
Tabletop Rotation Range	90°
Tabletop Sliding Range	400mm
Chair Sliding Range	160°
Input Voltage	AC110V/220(60/50Hz)
Weight	220kg



S-900A

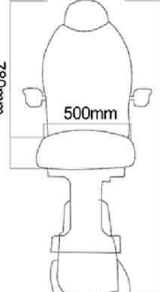

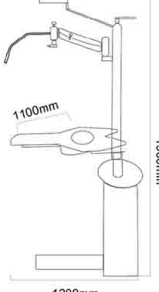



FEATURES

Unit Size	1200×1100×1900mm
Table Size	980×410×100mm
Table Movable Distance	90mm
Arm Up And Down Range	280mm
Chair Up And Down Range	160mm
Tabletop Rotation Range	355°
Chair Reclining Range	160°
Input Voltage	AC110V/220(60/50Hz)
Weight	220kg



S-900B

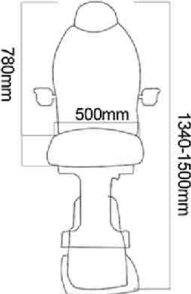

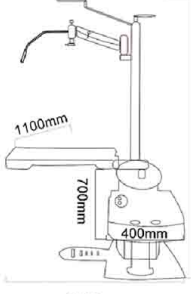



FEATURES

Unit Size	910×1080×1920mm
Table Size	880×500×120mm
Drawersize Size	530×370×60mm
Arm Movable Range	300mm
Tabletop Rotation Range	90°
Chair Lifting Height	160mm
Power Of Lamp	20W
Power	120W
Input Voltage	AC110V/220(60/50Hz)
Weight	150kg



FEATURES

Space Dimension Of Combined Platform (L x W x H)	98x85x186cm
Table Space Size	89x49x13cm
Mobile Small Table Size	30.5x45cm
Drawer Size	54.5x37x5cm
Left And Right Sliding Distance Of Moving Small Table	12-48cm, stroke 36cm
Rise And Fall Distance Of Hip Swing Of Comprehensive Tester	143-173cm, stroke 30cm
Height Of Projection Tray From The Ground	155cm
Space Dimension Of Electric Lift Chair	68x59x134.5cm
Lifting Distance Of Electric Lift Chair	119.5-134.5cm, stroke 15cm
Lighting Power	15W, 220V/50Hz
Total Power	165W
Outer Box Size	102x87x102cm

FEATURES

Space Dimension Of Combined Platform (L x W x H)	103x83x186cm
Table Space Size	103x50x13cm
Mobile Small Table Size	30x40cm
Drawer Size	54.5x37x5cm
Left And Right Sliding Distance Of Moving Small Table	6-46cm, stroke 40cm
Rise And Fall Distance Of Hip Swing Of Comprehensive Tester	143-173cm, stroke 30cm
Height Of Projection Tray From The Ground	155cm
Space Dimension Of Electric Lift Chair	68x59x134.5cm
Lifting Distance Of Electric Lift Chair	119.5-134.5cm, stroke 15cm
Lighting Power	15W, 220V/50Hz
Total Power	165W
Outer Box Size	92x50x105cm 110kg
Size Of Outer Box Of Table Top	115x61x27cm 38kg
Dimensions Of Lift Chair Outer Box	81.5x62.5x69cm 43kg



FEATURES

Large Table Size (L x W x H)	97x50x2.5cm
Small Table Size (L x W x H)	40x30x2.5cm
Sliding Stroke Of Small Table	0~42cm
Large Angle Rotating Table	0~90°
Wall Rotation Angle Of Comprehensive Tester	0~42°
Drawer Size (L x W x H)	54x38x6.5cm
Height Of Projection Tray From The Ground	150cm
Space Travel Of Electric Lift Chair	0~15cm
Lighting Voltage / Power	220V/6W
Total Power	120W
Main Body Outer Box Size	92x50x105cm 140kg
Size Of Outer Box Of Table Top	115x61x27cm 40kg
Dimensions Of Lift Chair Outer Box	81.5x62.5x69cm 45kg

FEATURES

Large Table Size (L x W x H)	97x50x2.5cm
Small Table Size (L x W x H)	40x30x2.5cm
Rotation Angle Of Small Table	0~180 degrees
Large Angle Rotating Table	0~90 degrees
Wall Rotation Angle Of Comprehensive Tester	0~90 degrees
Drawer Size (L x W x H)	54x38x6.5cm
Height Of Projection Tray From The Ground	150cm
Space Travel Of Electric Lift Chair	0~15cm
Lighting Voltage / Power	220V/6W
Total Power	120W
Main Body Outer Box Size	92x50x105cm 140kg
Size Of Outer Box Of Table Top	115x61x27cm 40kg
Dimensions Of Lift Chair Outer Box	81.5x62.5x69cm 45kg



镜盒
CASES

4 - 21

清洗液
SPRAY

22 - 24

镜布
MICROFIBER

25 - 31

纸袋
BAGS

32 - 33

设备
EQUIPMENT

35 - 65

设备配件
EQUIPMENT ACCESSORIES

66 - 94

钳子
PLIERS

95 - 102

螺丝
SCREWS

103 - 105

眼镜配件
GLASSES ACCESSORIES

106 - 121

镜绳
GLASSES CHAINS

122 - 126

道具
PROPERTY

128 - 137

镜架
FRAME

139 - 146

镜片
LENS

148 - 153

礼品
GIFTS

155 - 157

镜盒
CASES

4 - 21

清洗液
SPRAY

22 - 24

镜布
MICROFIBER

25 - 31

纸袋
BAGS

32 - 33

设备
EQUIPMENT

35 - 65

设备配件
EQUIPMENT
ACCESSORIES

66 - 94

钳子
PLIERS

95 - 102

螺丝
SCREWS

103 - 105

眼镜配件
GLASSES
ACCESSORIES

106 - 121

镜绳
GLASSES
CHAINS

122 - 126

道具
PROPERTY

128 - 137

镜架
FRAME

139 - 146

镜片
LENS

148 - 153

礼品
GIFTS

155 - 157



WZ-B

FEATURES

Chair Height	780-930mm
Back Height	330mm
Seat Width	440mm
Chair Up And Down Distance	150mm



WZ-C

FEATURES

Chair Height	1010-1170mm
Back Height	500mm
Seat Width	470mm
Chair Up And Down Distance	160mm



WZ-E-1

FEATURES

Chair Height	1010-1170mm
Back Height	500mm
Seat Width	450mm
Chair Up And Down Distance	160mm



WZ-DT-3

FEATURES

Chair Height	1210-1370mm
Back Height	690mm
Seat Width	510mm
Chair Up And Down Distance	160mm



WZ-DT-2

FEATURES

Chair Height	1200-1360mm
Back Height	690mm
Seat Width	510mm
Chair Up And Down Distance	160mm



WZ-AT-3

FEATURES

Chair Height	1200-1360mm
Back Height	690mm
Seat Width	510mm
Chair Up And Down Distance	160mm



WZ-AT-2

FEATURES

Chair Height	1250-1410mm
Back Height	740mm
Seat Width	500mm
Chair Up And Down Distance	160mm



WZ-DT-1

FEATURES

Chair Height	1340-1500mm
Back Height	780mm
Seat Width	500mm
Chair Up And Down Distance	160mm



WZ-DT-4

FEATURES

Chair Height	1200-1360mm
Back Height	720mm
Seat Width	540mm
Chair Up And Down Distance	160mm



WZ-Y5A-1

FEATURES

Chair Height	780-920mm
Back Height	310mm
Seat Width	380mm
Chair Up And Down Distance	140mm



WZ-Y5B

FEATURES

Chair Height	440-550mm
Back Height	325-150mm
Seat Width	340mm
Chair Up And Down Distance	110mm



JW-1005

FEATURES

Chair Height	840-1050mm
Back Height	250mm
Seat Width	420mm
Chair Up And Down Distance	840-1050mm



JW-103

FEATURES

Chair Height	660-870mm
Back Height	100mm
Seat Width	340mm
Chair Up And Down Distance	660-870mm



JW-517-1

FEATURES

Chair Height	910-1120mm
Back Height	320mm
Seat Width	430mm
Chair Up And Down Distance	910-1120mm



JW-108

FEATURES

Chair Height	390-550mm
Back Height	0
Seat Width	330mm
Chair Up And Down Distance	160mm

VT-5A



VT-10A



VT-5E



VT-10C



FEATURES

Sphere Powers Range	+16.75D to -19.00D, with minimum reading 0.25D or 0.12D (When +0.12D auxiliary lens or optional ±0.12D lens is in use) +26.75D to -29.00D (When optional ±10.00D lens is in use)
Cylinder Power Range	0 to -6.00D, with minimum reading 0.25D or 0.12D (when auxiliary lens is in use) 0 to -8.00D (when -2.00D auxiliary lens is in use)
Stigmatic Axis Scale	0 to 180° in 5° steps
Cross Cylinder	±0.25D, reversal type (synchronized with astigmatic axis)
Rotary Prism	0 to 20Δ in 1Δ step
Interpupillary Adjustment	48mm to 80mm in 1mm step (right and left synchronized)

Forehead Rest Adjustment	16mm backward and forward
Convergence	The optical axes of the lenses are aligned at a distance of 400mm from the vertexes of the corneas (2mm each for right and left inward) Interpupillary distance enabling convergence=57mm to 80mm
Corneal Distance Device	2mm forward and 5mm backward from standard plane; with scale
Effective Field Of View	19mm
Weight	5kg
Size	291-323x315x85

CV-7200



FEATURES

Cylinder	-6.00D~+6.00D 0.25D steps
Axis Angle	0~180°(1°/5°steps)
Pupil Distance	Distant range 52~80mm Close range 48~76mm 0.5/1mm steps
Rotary Prism	0~20A 0.1 /0.5/1.0A steps
Cross Cylinder Lens	±0.25D
Retinoscope	+1.50D(67cm), +2.00D(50cm) PH, Binocular(u=10mm) RMV、RMH RL(Right eye)、GL(Left eye)
Auxiliary Lens	Polaroid(Right eye 135°/45°r Left eye 45°/135°) Prism(Right 3ABU, 6ABU), (Left 3ABD, 10ABI) Cross Cylinder Lens(±0.50D Axis=90°) PD Lens
Phoropter Size	365mmx280mmx 110mm 3.8kg
Keyboard Size	230mmx195mmx 190mm 1.2kg
Power Box Size	236mmx126mmx 115mm 2.1kg
Power Supply	AC220V 50Hz or AC110V 60Hz, 90W

CV-7600



FEATURES

Cylinder	-19.00~+16.75D (0.25D/0.50D/1.00D/3.00D steps)
Axis Angle	-8.75D~+8.75D 0.25D steps
Pupil Distance	0-180° (1°/5°steps)
Rotary Prism	Distant range 52~80mm Close range 48~76mm 0.5/1 mm steps
Cross Cylinder Lens	0~20 A (0.1 A /0.5 Δ)
Retinoscope	±0.25D +1.50D(67cm), +2.00D(50cm) PH, Binocular (C =1.0mm) RMV/RMH RL(Right eye)、GL (Left eye)
Auxiliary Lens	Polaroid (Right eye 135°/45°), (Left eye 45°/135°) Prism (Right 3 A BU , 6 A BU) , (Left 3 Δ BD, 10 A BI) Cross Cylinder Lens(±0.50D Axis=90°) PD Lens
Phoropter Size	381mmx286mmx115mm 3.8kg
Keyboard Size	243mmx126mmx 77mm 0.5kg
Power Box Size	243mmx126mmx 77mm 0.5kg
Power Supply	AC220V 50Hz or AC110V 60Hz, 90W

镜盒
CASES

4-21

清洗液
SPRAY

22-24

镜布
MICROFIBER

25-31

纸袋
BAGS

32-33

设备
EQUIPMENT

35-65

设备配件
EQUIPMENT
ACCESSORIES

66-94

钳子
PLIERS

95-102

螺丝
SCREWS

103-105

眼镜配件
GLASSES
ACCESSORIES

106-121

镜绳
GLASSES
CHAINS

122-126

道具
PROPERTY

128-137

镜架
FRAME

139-146

镜片
LENS

148-153

礼品
GIFTS

155-157

- 镜盒
CASES
- 4-21
- 清洗液
SPRAY
- 22-24
- 镜布
MICROFIBER
- 25-31
- 纸袋
BAGS
- 32-33
- 设备
EQUIPMENT
- 35-65
- 设备配件
EQUIPMENT
ACCESSORIES
- 66-94
- 钳子
PLIERS
- 95-102
- 螺丝
SCREWS
- 103-105
- 眼镜配件
GLASSES
ACCESSORIES
- 106-121
- 镜绳
GLASSES
CHAINS
- 122-126
- 道具
PROPERTY
- 128-137
- 镜架
FRAME
- 139-146
- 镜片
LENS
- 148-153
- 礼品
GIFTS
- 155-157

CP-300



CP-400



FEATURES

Projection Distance	2.0 ~ 7.0m
Projection Magnification	30 (when the projection distance of 5m)
Projection Size	335mm x 222mm (when the projection distance of 5m)
Tilt Angle	from the horizon up or down for each 10 degrees
Source	12V 35W (halogen)
Dimensions	248 (W) x 336 (L) x 234 (H)
Weight	4kgs
Power Supply	100-240V

120VA 5 minutes after the power automatically turn off

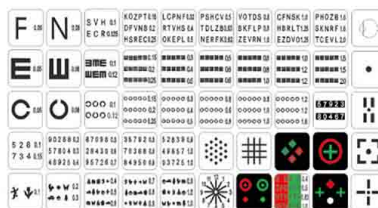

FEATURES

Projection Distance	1.5 ~ 6m
Projection Magnification	30 (when the projection distance of 5m)
Projection Size	335mm x 222mm (when the projection distance of 5m)
Tilt Angle	from the horizon up or down for each 10 degrees
Source	12V 30W (halogen)
Dimensions	300 (W) x 230(L) x 240 (H)
Weight	6kgs
Power Supply	AV220V



CP-60

JG-1



FEATURES

Up/Down Angle Of Arm	±30°
Rotate Angle Of Arm	180°
Loading For View Tester	10kgs
Loading For Chart Projector	10kgs

JG-2



FEATURES

Up/Down Angle Of Arm	±30°
Input Voltage	110V/220V AC50Hz ~ 60Hz
Lamp Power	36W
Working Temperature	-30°C ~ +50°C
Relative Humidity	less than 90%
Figure Size	600mmx745mmx2063mm
Weight	55kgs
Wooden Case Size	660 mm x495 mm x190 mm
Carton Size	1050 mm x700 mm x120 mm

JG-3



FEATURES

Up/Down Angle Of Arm	±30°
Input Voltage	110V/220V AC50Hz ~ 60Hz
Lamp Power	36W
Working Temperature	-30°C ~ +50°C
Relative Humidity	less than 90%
Figure Size	600mmx745mmx2063mm
Weight	55kgs
Wooden Case Size	660 mm x495 mm x190 mm
Carton Size	1050 mm x700 mm x120 mm

LE-310



FEATURES

Size	about 530×500×400mm
Weight	about 50Kg
Rated Frequency	50~60Hz
Noise	≤50DB
Voltage	220V±10% (The voltage is 110V :requires specific)
Electric Power Consumption	≤500W
Main Motor Power	380W
Work Environment Requirements	5 C~40 C

LE-400
(带PC)



FEATURES

Size	about 530×500×400mm
Weight	about 50Kg
Rated Frequency	50~60Hz
Noise	≤50DB
Voltage	220V±10% (The voltage is 110V :requires specific)
Electric Power Consumption	≤500W
Main Motor Power	380W
Work Environment Requirements	5 C~40 C

LE-1000



FEATURES

Out Size	650mm×550mm×480mm
Weight	60kg
Hz	50Hz
Sounds	≤80DB
Voltage	220V±10% (110V Can be customized)
Power	≤500W
Power Of Main Motor	380W
Working Environment	5 C~40 C

LE-1200



FEATURES

Size	705mm×465mm×442mm
Weight	65kg
Input Voltage	220V-230V/50Hz, 110V-115V/60Hz
Machine Power	1500W
Noise	72db
Operating Temperature	5 C~40 C
relative Humidity	10% - 80%
Pump Working Voltage	220V-230V /50Hz, 110V-115V /60 Hz
Pump Rated Power	<=150W
FUSE	220V-230V /50HZ==15A 110V-115V /60Hz==25A

LE-1600



FEATURES

Size	705mm×465mm×442mm
Weight	75kg
Input Voltage	220V-230V/50Hz, 110V-115V/60Hz
Machine Power	1500W
Noise	72db
Operating Temperature	5 C~40 C
Relative Humidity	10% - 80%
Pump Working Voltage	220V-230V /50Hz, 110V-115V /60 Hz
Pump Rated Power	<=150W
FUSE	220V-230V /50HZ==15A 110V-115V /60Hz==25A

镜盒
CASES

4 - 21

清洗液
SPRAY

22 - 24

镜布
MICROFIBER

25 - 31

纸袋
BAGS

32 - 33

设备
EQUIPMENT

35 - 65

设备配件
EQUIPMENT
ACCESSORIES

66 - 94

钳子
PLIERS

95 - 102

螺丝
SCREWS

103 - 105

眼镜配件
GLASSES
ACCESSORIES

106 - 121

镜绳
GLASSES
CHAINS

122 - 126

道具
PROPERTY

128 - 137

镜架
FRAME

139 - 146

镜片
LENS

148 - 153

礼品
GIFTS

155 - 157

- 镜盒
CASES
- 4 - 21
- 清洗液
SPRAY
- 22 - 24
- 镜布
MICROFIBER
- 25 - 31
- 纸袋
BAGS
- 32 - 33
- 设备
EQUIPMENT
- 35 - 65
- 设备配件
EQUIPMENT
ACCESSORIES
- 66 - 94
- 钳子
PLIERS
- 95 - 102
- 螺丝
SCREWS
- 103 - 105
- 眼镜配件
GLASSES
ACCESSORIES
- 106 - 121
- 镜绳
GLASSES
CHAINS
- 122 - 126
- 道具
PROPERTY
- 128 - 137
- 镜架
FRAME
- 139 - 146
- 镜片
LENS
- 148 - 153
- 礼品
GIFTS
- 155 - 157

SJG-5099/SJG-5199
(SJG-5199带PC)



FEATURES

Lens Diameter	Φ18-Φ80(mm)
Power Of Clamping Lens	0.45-1.10mpa(three choices)
Power Consumption	<=396W
Working Environment Temperature	5 C -4 C
Dimension	61x41x47(cm)
Optional Diameter Of The Grinding Wheel	Φ100mm
Weight	59kgs
Power And Frequency	AC,220V(110V)/50HZ(60Hz)
Working Speed Of The Grinding Wheel	16.7m/s
System	circular of direct water supply(optional)

GIFT



CP-10C

CP-5D

FEATURES

Lens Diameter	Φ18-Φ80(mm)
Power Of Clamping Lens	0.45-1.10mpa(three choices)
Power Consumption	<=396w
Working Environment Temperature	5 C -4 C
Dimension	61x41x47(cm)
Optional Diameter Of The Grinding Wheel	Φ100mm
Weight	59kgs
Power And Frequency	AC,220V(110V)/50HZ(60HZ)
Working Speed Of The Grinding Wheel	16.7m/s
System	circular of direct water supply(optional)

SJG-5299/SJG-5399
(SJG-5399带PC)



FEATURES

Dimension	625x510x510mm
Weight	49kg
Voltage	AC220V/110V 50/60Hz
Power	550W
Size range	22-80mm
Clamping presstire	Thied gear adjustable
Wheel diameter	100mm

FEATURES

Dimension	240x180x130mm
Weight	5kg
Voltage	AC220V/110V 50/60Hz
Power	60W
Scween tiltangle	20-100
Touch screen	7 inch capacitive screen
Quantity of connecting with the main machine	2

SJG-800





RM-9000



RM-9200



RM-9600

FEATURES

VD	0, 12, 13.75, 15mm
Spherical Power	-20~+20D(0.12/0.25D steps)(VD=12mm)
Astigmatic Power	0~10D(0.12/0.25D steps)
Axies	1~180°(each steps 1°)
PD Distane	45~85mm
Min Pupil Size	φ2mm
Chart	auto fog
Screen	5.7in LCD screen
Built-in Printer	thermal printer
Save Electricity	5~15minute Auto screen saver
Dimension (L×W×H)	288×500×480mm
Weight	14kg
Power Requirement	AC 100~240V 50/60Hz



KR-9000



KR-9200



KR-9600

FEATURES

K/R Pattern	Measuring dioptrascopy and keratometry
REF Pattern	Measuring dioptrascopy keratometry
KER Pattern	Measuring keratometry
VD	0, 12, 13.75, 15mm
Spherical Power	-20~+20D(0.12/0.25D steps)(VD=12mm)
Astigmatic Power	0~10D(0.12/0.25D steps)
Axies	1~180°(each steps 1°)
PD Distane	30~85mm
Min Pupil Size	φ2mm
Chart	auto fog
Corneal Curvature Radius	5~10mm(0.01mm steps)
Corneal Diopter	30~67D(0.12/0.25D steps)
Corneal Astigmatism	0~15D(0.12/0.25D steps)
Axies	1~180°(each steps 1°)
Corneal Diameter	2~12mm
Screen	5.7in LCD screen
Built-in Printer	thermal printer
Save Electricity	5~15minute Auto screen saver
Dimension (L×W×H)	288×500×480mm
Weight	14.5kg
Power Requirement	AC 100~240V 50/60Hz

镜盒 CASES	4 - 21
清洗液 SPRAY	22 - 24
镜布 MICROFIBER	25 - 31
纸袋 BAGS	32 - 33
设备 EQUIPMENT	35 - 65
设备配件 EQUIPMENT ACCESSORIES	66 - 94
钳子 FILERS	95 - 102
螺丝 SCREWS	103 - 105
眼镜配件 GLASSES ACCESSORIES	106 - 121
镜绳 GLASSES CHAINS	122 - 126
道具 PROPERTY	128 - 137
镜架 FRAME	139 - 146
镜片 LENS	148 - 153
礼品 GIFTS	155 - 157

- 镜盒
CASES
- 4 - 21
- 清洗液
SPRAY
- 22 - 24
- 镜布
MICROFIBER
- 25 - 31
- 纸袋
BAGS
- 32 - 33

设备
EQUIPMENT

35 - 65

- 设备配件
EQUIPMENT
ACCESSORIES

66 - 94

- 钳子
PLIERS

95 - 102

- 螺丝
SCREWS

103 - 105

- 眼镜配件
GLASSES
ACCESSORIES

106 - 121

- 镜绳
GLASSES
CHAINS

122 - 126

- 道具
PROPERTY

128 - 137

- 镜架
FRAME

139 - 146

- 镜片
LENS

148 - 153

- 礼品
GIFTS

155 - 157

FA-6100A



FA-6500



FEATURES

K/R	Measuring Dioptrics And Keratometry
REF	PD distane
KER	Measuring Keratometry
VD	0.0,12.0,13.75,15.0mm
Spherical Power	-20.00~+20.00D (0.12/0.25D in steps) (VD=12mm)
Astigmatic Power	0.00- ±10.00D (0.12/0.25D /steps)
Axis	1° -180° (each steps 1°)
PD Distance	30~85mm
Min Pupil Size	φ2.0mm
Chart	auto fog
Corneal Curvature Radius	5-10mm (0.01 mm /steps)
Corneal Diopter	30.00-67.00D (0.12/0.25D /steps)
Corneal Astigmatism	00.00~15.00D (0.12/0.25D /steps)
Axis	1° -180° (each steps 1°)
Corneal Diameter	2.0~ 12mm
Screen	5.7 in LCD screen
Built-in Printer	Thermal Printer
Save Electricity	5~ 15minute auto screen saver
Power	Ac100-240V,50/60HZ
Size/Weight	288(W)x500(D)x480(H).mm/14.5kg

FA-6800



RMK-8000



FEATURES

Vertex Distance	0.0mm,12.00mm,13.5mm,15.00mm
Spherical Degree	-20.00D~20.00D,(VD=12mm step: 0.12D/0.25D)
Cylinder Degree	0.00D~10.00D(step: 0.12D/0.25D)
Axis	1°~180°(step1°)
Cylinder Symbol	MIX
The Degree Of Arming Turning	90°
Minimum Pupil Diameter	2.0mm
Radius Of Curvature	6.5mm~9.4mm(step: 0.02mm)
Printer	Thermal printer
Monitors	6.4 inch of TFT monitors
Power Supply	AC110-240V, 50/60Hz
Weight	About 21Kg

FR-710



FEATURES

K&R Mode	Dioptr and corneal curvature measurements
REF Mode	Dioptr measurement
KRT Mode	Dioptr and corneal curvature
Vertex Distance(VD)	0mm,12.00mm,13.75mm,15.00mm
Spherical Refractive Power	*-25.00D~+20.00D
Cylindrical Refractive Power	0D~8D
Direction Of Astigmaticxis	0°~180°
PD Measurement	45mm~85mm
Minimum Pupil Diameter	φ2.0mm
Cornea Curvature Radius	6.5mm~9.4mm
Direction Of Corneal Astigmatic Axis	0°~180°
Cornea Diameter	2.0mm~12.0mm
Monitor	9" Touch LCD monitor
Printer	Auto-Cut Data Paper
Saving Mode	1/5/10/20/40 minutes antomatic screensaver
Power Supply	AC220V; 50HZ 75CA
Dimension/Weight	300(W)*450(D)*500-530(H)MM/20kg

JD-2000



JD-2000B



D-900



FEATURES

Sphere	0~±25m" 0.01/0.12/0.25m"1 step
Cylinder	0~±9.99nT1 0.01/0.12/0.25nrT1 step
Axis	0~180° (1°step)
Add	0~+9.99m" 0.01/0.12/0.25m"1 step
Prism Degree	0~15 0.01/0.12/0.25m-1 step
Prism	X-Y,P-B
Contact Lens	Soft/hard lens
Measuring Mode	Single/progressive/ automatic recognition
Diameter Of Lens	020-0108mm

PD	40~90mm, 0.5mm step
Speed Of Measurement	0.1 second
Display	7"LCD/TF
Printer	JD-2600&JD-2000:Thermal Printer JD-2000B:Without Printer
Dimension	JD-2600:216mmx300mmx456mm JD-2000&JD-2000B:196mmx286mmx442mm
Weight	~6kg
Power Supply	100-240V 50~60Hz



镜盒
CASES

4 - 21

清洗液
SPRAY

22 - 24

镜布
MICROFIBER

25 - 31

纸袋
BAGS

32 - 33

设备
EQUIPMENT

35 - 65

设备配件
EQUIPMENT
ACCESSORIES

66 - 94

钳子
PLIERS

95 - 102

螺丝
SCREWS

103 - 105

眼镜配件
GLASSES
ACCESSORIES

106 - 121

镜绳
GLASSES
CHAINS

122 - 126

道具
PROPERTY

128 - 137

镜架
FRAME

139 - 146

镜片
LENS

148 - 153

礼品
GIFTS

155 - 157

JD-2600A



JD-2600B



LM-700



FEATURES

Sphere	0- ±25D 0.01/0.12/0.25D step
Cylinder	0~ ±9.99D 0.01/0.12/0.25D step
Axis	0°~180° (1° step)
Add	0- ±9.99D 0.01/0.12/0.25D step
Prism Degree	0~15 A0.01/0.12/0.25D step
Prism	X-Y,P-B
Contact Lens	Softy/hard
Measuring Mode	Single/progressive/automatic recognition
Diameter Of Lens	20~108mm
PD	40~90mm,0.5mm step
Speed Of Measurement	0.1s
Display	7M TFT LCD
Printer	JD-2000:Thermal Printer JD-2000B:No Printer
Weight	~5KG
Power Supply	100~240V 50~60HZ



FEATURES

Sphere	0- ±25D 0.01/0.12/0.25D step
Cylinder	0~ ±9.99D 0.01/0.12/0.25D step
Axis	0°~180° (1° step)
Add	0- ±9.99D 0.01/0.12/0.25D step
Prism Degree	0~15 A0.01/0.12/0.25D step
Prism	X-Y,P-B
Contact Lens	Softy/hard
Measuring Mode	Single/progressive/automatic recognition
Diameter Of Lens	20~108mm
PD	40~90mm,0.5mm step
Speed Of Measurement	0.1s
Display	7M TFT LCD
Printer	JD-2000:Thermal Printer JD-2000B:No Printer
Weight	~5KG
Power Supply	100~240V 50~60HZ

- 镜盒
CASES
- 4 - 21
- 清洗液
SPRAY
- 22 - 24
- 镜布
MICROFIBER
- 25 - 31
- 纸袋
BAGS
- 32 - 33
- 设备
EQUIPMENT
- 35 - 65
- 设备配件
EQUIPMENT
ACCESSORIES
- 66 - 94
- 钳子
PLIERS
- 95 - 102
- 螺丝
SCREWS
- 103 - 105
- 眼镜配件
GLASSES
ACCESSORIES
- 106 - 121
- 镜绳
GLASSES
CHAINS
- 122 - 126
- 道具
PROPERTY
- 128 - 137
- 镜架
FRAME
- 139 - 146
- 镜片
LENS
- 148 - 153
- 礼品
GIFTS
- 155 - 157



HV-100

FEATURES

Sphere Measurement Range	-25.00DS ~ +25.00DS Steps: 0.01DS/0.12DS/0.25DS
Cylinder Measurement Range	0.00 ~ ±10.00DC Measurement mode: Mix/ + / - Steps 0.01DC/0.12DC/0.25DC
Cylinder Axis Measurement Range	0° ~ 180° Steps: 1°
ADD Measurement Range	-10DS ~ +10DS Steps: 0.01DS/0.12DS/0.25DS
Prism Measurement Range	0 ~ 20△ Measurement mode: X-Y rectangular coordinates
Steps	0.01△ / 0.12△ / 0.25△
Measurable Lens Diameter	φ20mm ~ φ100 mm
Measurable Lens Center Thickness	≤20mm
PD Measurement Range	42mm ~ 82mm
Vertex Power Measure Wave Length	525nm , UV Measure Wave Length 400nm
Power Supply	DC 5V 6A
Rated Power	30VA

NJC-4

NJC-5

NJC-6

NJC-6A



FEATURES

Eyegight Adjustment Range	±5D	Cixiconrcinge	0-180°
Dioptrymetry Test Range	-25D~+25D	Cixicon Value	1°
Min Measurement Range	0.125D	Lenz Diameter	100mm
Prism Dioptry Test Range	18A	AC	200V/110V/6V
Prism Value	1A	DC	3V

NJC-7

NJC-7A



FEATURES

Eyepiece Focusing Range	±5D
The Top Point Dioptry Measuring Range	-25D~+25D
The Minimum Measuring Square Value	0.125D
The Shuttle Lens Measuring Range	10△
The Shuttle Lens Square Value	1△
The Cylinder Lens Axial Range	0—180°
The Cylinder Lens Axial Square Value	1°
The Maximum Diameter Of The Measured Lenses	100mm
The Lighting	AC:220V/110V-6V DC:3V

YZ6E



FEATURES

illumination Style	Large Spot, Small Spot, Slit, Mesh, Red-free
Diopter Compensation	-35D~+20D, 24 steps in total
Illumination Source	6V/5W, Halogen Bulb
Illuminance	≥80Lx
Power Supply	AC220V±10%, 50Hz±Hz
Input Power	6VA

YZ6H



FEATURES

Diopter Compensation	0, ±1, ±2, ±3, ±4, ±5, ±6, ±8, ±10, ±12, ±15, ±20, -25, -3ED
Light Source	3.5V/1W LED
Input Voltage	AC220V±10%, 50Hz

YZ24



FEATURES

Working Distance	1m
Streak	3mm~20mm
Streak Rotation	360°
Illumination Source	3V/2.1W, halogen bulb
Input Voltage	AC220V±10%, 50Hz

YZ6G



FEATURES

illumination Style	Large Spot, Small Spot, Slit, Mesh, Red-free
Diopter Compensation	-35D~+20D 24 steps in total
Illumination Source	6V/5W Halogen Bulb
Color rendering Index	≥90%
Illuminance	≥80Lx
Power Supply	AC220V/50HZ
Input Power	8VA

YZ11



FEATURES

Working Distance	1m
Streak	3mm~20mm
Streak Rotation	360°
Illumination Source	3V/2.1W, halogen bulb
Input Voltage	AC220V±10%, 50Hz

YZ11D



FEATURES

illumination Style	Large Spot, Small Spot, Slit, Mesh, Red-free
Diopter Compensation	-35D~+20D 24/steps in total
Illumination Source	3.5V/2.8W halogen bulb
Power	Li+/battery packDC: 3.7V
Input Voltage	AC110V-240V 50Hz/60Hz

YZ24B



FEATURES

Light Source	3.5V/2.8W
Input Voltage	AC110V-240V 50Hz/60Hz
Power	Li+/Battery Pack DC: 3.7V
Power Consumption	20VA

YZ25B



FEATURES

illumination Style	Large Spot, Small Spot, Slit, Mesh, Red-free
Diopter Compensation	-35D~+20D 24/steps in total
Illumination Source	3.5V/2.8W/halogen bulb
Power	Li+/battery packDC: 3.7V
Input Voltage	AC110V-240V 50Hz/60Hz

YZ25C



FEATURES

Pupillary Accommodation	52-74mm Adjustable in range
Illumination Brightness	Continuously stepless adjustable
Head Adjustment	520~640mm/The head circumference
Light Spot	There are three kinds of larvae soot, middle soot and small soot
Color Filter	No red, colorless, blue
Lighting Source	LED light
Color Rendering Index	≥90%

镜盒
CASES

4 - 21

清洗液
SPRAY

22 - 24

镜布
MICROFIBER

25 - 31

纸袋
BAGS

32 - 33

设备
EQUIPMENT

35 - 65

设备配件
EQUIPMENT ACCESSORIES

66 - 94

钳子
PLIERS

95 - 102

螺丝
SCREWS

103 - 105

眼镜配件
GLASSES ACCESSORIES

106 - 121

镜绳
GLASSES CHAINS

122 - 126

道具
PROPERTY

128 - 137

镜架
FRAME

139 - 146

镜片
LENS

148 - 153

礼品
GIFTS

155 - 157

- 镜盒
CASES
- 4 - 21
- 清洗液
SPRAY
- 22 - 24
- 镜布
MICROFIBER
- 25 - 31
- 纸袋
BAGS
- 32 - 33
- 设备
EQUIPMENT
- 35 - 65
- 设备配件
EQUIPMENT ACCESSORIES
- 66 - 94
- 钳子
PLIERS
- 95 - 102
- 螺丝
SCREWS
- 103 - 105
- 眼镜配件
GLASSES ACCESSORIES
- 106 - 121
- 镜绳
GLASSES CHAINS
- 122 - 126
- 道具
PROPERTY
- 128 - 137
- 镜架
FRAME
- 139 - 146
- 镜片
LENS
- 148 - 153
- 礼品
GIFTS
- 155 - 157

BL6A

FEATURES

Microscope Type	Galean stereoscopic microscope
Magnification Selection	5 steps by dun rotation
Eyeiece	12.5x
Magnificatio Ratio	6×(φ33mm)、10×(φ22.5)、16×φ14mm)、 25×(φ8.8mm)、40×(φ5.5mm)
Pupillary Adjustment	52mm-80mm
Diopter Adjustment	+7D—7D
Side Shift	110mm
Base Depth Shift	90mm
Base Height Shift	30mm
Chin Rest Height Shift	80mm
Chin Rest Fixation Target	LED/Redled
Slit Width	0~14mm continuous (at14 mm slit becomes adjustable)
Slit Height	1~14mm continuous
Slit Angle	0~180°Adjustable
Diameter Of Light Spot	φ14mm、φ10mm、φ5mm、φ3mm、 φ2mm、φ1mm、φ0.2mm、φ1mm、 φ1-14mm Continuous
Filter	Heat absorption, grey, red-free, cobalt blue
Illumination Bulb	12V 50W halogen lap
Input Voltage	220V/AC
Frequency	50HZ
Power Consumption	68VA
Gross Weight	18kg
Net Weight	16km
Dimension	690mm×440mm×420mm



BL66C



FEATURES

Microscope Type	Galean stereoscopic microscope
Magnification Selection	5 steps by dun rotation
Eyeiece	12.5x
Magnificatio Ratio	6×(φ33mm)、10×(φ22.5)、16×φ14mm)、 25×(φ8.8mm)、40×(φ5.5mm)
Pupillary Adjustment	52mm-80mm
Diopter Adjustment	+7D—7D
Side Shift	110mm
Base Depth Shift	90mm
Base Height Shift	30mm
Chin Rest Height Shift	80mm
Chin Rest Fixation Target	Red led
Slit Width	0~14mm continuous (at14 mm slit becomes adjustable)
Slit Height	1~14mm continuous
Slit Angle	0~180°Adjustable
Slit Inclination	5°、10°、15°、20°
Diameter Of Light Spot	φ14mm、φ10mm、φ5mm、φ3mm、 φ2mm、φ1mm、φ0.2mm、φ1mm、 φ1-14mm Continuous
Filter	Heat absorption, grey, red-free, cobalt blue
illumination Bulb	12V 50W halogen lap
Maximum Illumination	≥22000lx
Input Voltage	220V/AC
Frequency	50HZ
Power Consumption	68VA
Gross Weight	18kg
Net Weight	16km
Dimension	690mm×440mm×420mm

BL88

FEATURES

Microscope Type	Galean stereoscopic microscope
Magnification Selection	3 steps by dun rotation
Eyeiece	12.5x
Magnificatio Ratio	10×(φ22.5)、16×φ14mm)、25×(φ8.8mm)
Pupillary Adjustment	52mm-80mm
Diopter Adjustment	+7D—7D
Side Shift	110mm
Base Depth Shift	90mm
Base Height Shift	30mm
Chin Rest Height Shift	80mm
Chin Rest Fixation Target	Red led
Slit Width	0~14mm continuous (at14 mm slit becomes adjustable)
Slit Height	1~14mm continuous
Slit Angle	0~180°Adjustable
Slit Inclination	5°、10°、15°、20°
Diameter Of Light Spot	φ14mm、φ10mm、φ5mm、φ3mm、 φ2mm、φ1mm、φ0.2mm、φ1mm、 φ1-14mm Continuous
Filter	Heat absorption, grey, red-free, cobalt blue
illumination Bulb	12V 50W halogen lap
Maximum Illumination	≥22000lx
Input Voltage	220V/AC
Frequency	50HZ
Power Consumption	68VA
Gross Weight	18kg
Net Weight	16km
Dimension	690mm×440mm×420mm



FEATURES

Microscope Type	Galean stereoscopic microscope
Magnification Selection	3 steps by dun rotation
Eyeiece	12.5x
Magnificatio Ratio	10×(φ22.5)、16×φ14mm)、25×(φ8.8mm)
Pupillary Adjustment	52mm-80mm
Diopter Adjustment	+7D—7D
Side Shift	110mm
Base Depth Shift	90mm
Base Height Shift	30mm
Chin Rest Height Shift	80mm
Chin Rest Fixation Target	Red led
Slit Width	0~14mm continuous (at14 mm slit becomes adjustable)
Slit Height	1~14mm continuous
Slit Angle	0~180°Adjustable
Slit Inclination	5°、10°、15°、20°
Diameter Of Light Spot	φ14mm、φ10mm、φ5mm、φ3mm、 φ2mm、φ1mm、φ0.2mm、φ1mm、 φ1-14mm Continuous
Filter	Heat absorption, grey, red-free, cobalt blue
Illumination Bulb	12V 50W halogen lap
Maximum Illumination	≥220000lx
Input Voltage	220V/AC
Frequency	50HZ
Power Consumption	68VA
Gross Weight	18kg
Net Weight	16km
Dimension	690mm×440mm×420mm

BL88T



BL88D



FEATURES

Microscope Type	Galean stereoscopic microscope
Magnification Selection	5 steps by dun rotation
Eyeiece	12.5x
Magnificatio Ratio	6×(φ33mm)、10×(φ22.5)、16×φ14mm) 、 25×(φ8.8mm)、40×(φ5.5mm)
Pupillary Adjustment	52mm-80mm
Diopter Adjustment	+7D—7D
Side Shift	110mm
Base Depth Shift	90mm
Base Height Shift	30mm
Chin Rest Height Shift	80mm
Chin Rest Fixation Target	Red led
Slit Width	0~14mm continuous (at14 mm slit becomes adjustable)
Slit Height	1~14mm continuous
Slit Angle	0~180°Adjustable
Slit Inclination	5°、10°、15°、20°
Diameter Of Light Spot	φ14mm、φ10mm、φ5mm、φ3mm、 φ2mm、φ1mm、φ0.2mm、φ1mm、 φ1-14mm Continuous
Filter	Heat absorption, grey, red-free, cobalt blue
Illumination Bulb	12V 50W halogen lap
Maximum Illumination	≥220000lx
Input Voltage	220V/AC
Frequency	50HZ
Power Consumption	68VA
Gross Weight	18kg
Net Weight	16km
Dimension	690mm×440mm×420mm

FEATURES

Microscope Type	Converging Stereoscope Microscope
Magnification Selection	5 steps by dun rotation
Eyeiece	12.5x
Magnificatio Ratio	6×(φ33mm)、10×(φ22.5)、16×φ14mm) 、 25×(φ8.8mm)、40×(φ5.5mm)
Pupillary Adjustment	52mm-80mm
Diopter Adjustment	+7D—7D
Side Shift	110mm
Base Depth Shift	90mm
Base Height Shift	30mm
Chin Rest Height Shift	80mm
Chin Rest Fixation Target	Red led
Slit Width	0~14mm continuous (at14 mm slit becomes adjustable)
Slit Height	1~14mm continuous
Slit Angle	0~180°Adjustable
Slit Inclination	5°、10°、15°、20°
Diameter Of Light Spot	φ14mm、φ10mm、φ5mm、φ3mm、 φ2mm、φ1mm、φ0.2mm、φ1mm、 φ1-14mm Continuous
Filter	Heat absorption, grey, red-free, cobalt blue
Illumination Bulb	12V 50W halogen lap
Maximum Illumination	≥220000lx
Input Voltage	220V/AC
Frequency	50HZ
Power Consumption	68VA
Gross Weight	18kg
Net Weight	16km
Dimension	690mm×440mm×420mm

BL99



镜盒
CASES

4 - 21

清洗液
SPRAY

22 - 24

镜布
MICROFIBER

25 - 31

纸袋
BAGS

32 - 33

设备
EQUIPMENT

35 - 65

设备配件
EQUIPMENT
ACCESSORIES

66 - 94

钳子
PLIERS

95 - 102

螺丝
SCREWS

103 - 105

眼镜配件
GLASSES
ACCESSORIES

106 - 121

镜绳
GLASSES
CHAINS

122 - 126

道具
PROPERTY

128 - 137

镜架
FRAME

139 - 146

镜片
LENS

148 - 153

礼品
GIFTS

155 - 157

镜盒
CASES

4-21

清洗液
SPRAY

22-24

镜布
MICROFIBER

25-31

纸袋
BAGS

32-33

设备
EQUIPMENT

35-65

设备配件
EQUIPMENT
ACCESSORIES

66-94

钳子
PLIERS

95-102

螺丝
SCREWS

103-105

眼镜配件
GLASSES
ACCESSORIES

106-121

镜绳
GLASSES
CHAINS

122-126

道具
PROPERTY

128-137

镜架
FRAME

139-146

镜片
LENS

148-153

礼品
GIFTS

155-157

BL5000



FEATURES

Microscope Type	Converging Stereoscope Microscope
Magnification Selection	Two Steps Magnifications
Eye-piece	10x 16x
Diopter Adjustment	+7D-7D
Pupillary Adjustment	45mm-70mm
Working Distance	80mm
Slit Width	0~10mm continuous (at 10mm slit becomes adjustable)
Diameter Of Light Spot	φ10mm、φ5mm、φ3mm、φ1mm
Slit Angle	±30°
Chin Rest Fixation Target	Height Light Led
Maximum Illumination	≥3000lx
Power	7.4V 2200MA Li Battery Rechargeable
Working Time	5-6 hours
Net Weight	9kg
Dimension	216mm×100mm×225mm

BL8002



FEATURES

Corneal Radius Of Curvature	5.5-12mm
Minum Reading	0.02mm
Corneal Refractive Power	30-60D
Minum Reading	0.25D
Axis Of Corneal Astigmatism	0 to 180°
Minum Reading	1°
Diopter Adjustment Scale	0~±5dptr
Illumination bulb R=5.5mm	φ1.65mm
Illumination bulb R=7.5mm	φ2.36mm
Illumination bulb R=11mm	φ3.36mm
Voltage/Frequency	220V/50HZ
Dimension	450mm×300mm×450mm
Net Weight	16kg

BL8003



FEATURES

Corneal Radius Of Curvature	5.5-12mm
Minum Reading	0.02mm
Corneal Refractive Power	28-60D
Minum Reading	0.125D
Axis Of Corneal Astigmatism	0 to 180°
Minum Reading	1°
Diopter Adjustment Scale	0~±5dptr
Illumination Bulb R=5.5mm	φ1.65mm
Illumination Bulb R=7.5mm	φ2.36mm
Illumination Bulb R=11mm	φ3.36mm
Voltage/Frequency	220V/50HZ
Dimension	330mm×280mm×430mm
Net Weight	15kg

电脑视力检测仪
LCD Visual Tester

CP-27A



LYPG-12



FEATURES

Size	15 dimensions
Input Power Parameter	AC100V-240V/20HZ/60HZ
Standard Power Consumption	20W
Standby Power Consumption	<2W
Maximum Resolution Of Screen	1366×768
Screen Type	LED
Screen Scale	0.672916667
Dimensions(L×W×H)	463×48×337mm
Support Wall Hanging	100×100mm
Weight	5kg
Use Distance	1-7m
Visual Recording Method	Decimal, English fraction recording method
Remote Control Distance	Maximum remote control distance 8m

FEATURES

Parameter	19"
Rated Power	45W
Standby Power	2W
Screen Resolution Ratio	1440X900@60Hz
Dot Pitch	0.284mm
Screen Ratio	TFT
Screen Type	16:09
Screen Size	19"
Visible Angle	408.24mmX222.15mm
Visible Size	H: 170/V: 160
Color	16. 7M
Max. Brightness	300cd/m2
Max.Contrast Ratio	1900-3-23 8:01:00
Signal Response Time	5ms
Overall Size(mm)	460×355×200mm
Weight	5.0kg(6.2kg)
Effective Distance	2m~5m (Adjustable)

视力测试软件
Visual Software

CP-27B



FEATURES

The screen displays 9 palace operation program modes, and the operation method is simple and easy to use at a glance, including 9 Series vision chart:

1. International standard vision chart (e-word vision chart)
 2. Langmuir ring vision chart (C-word vision chart)
 3. Latin alphabet visual acuity chart (ABC word visual acuity chart)
 4. Arabic digital vision chart (123 word vision chart)
 5. Children's vision chart
 6. Astigmatism test sight
 7. Color blindness test visual standard
 8. Comprehensive test vision
 9. Ophthalmology knowledge map
- Optional test distance: 6.3m, 5m, 4m, 3M, 2.5m, 2m, 1.5m, 1.2m, 1m

FEATURES

Dimensions(L×W×H)	265×200×80mm/265×220×110mm/325×220×110mm
Weight	0.8kg
Power Requirement	6V DC(IrO3 batteries×4)
Left And Right Pupil Distance	22.5-41 mm
Indication Error	≤0.5mm
Rounding Error	≤0.5mm
Measurable Monocular Target Distance	30cm
Indication Error	0.5mm

Main feature use exactitude optical configuration,measure more correctly, with adjustable knob,adjust the distance. Method of measurement: reflection light coincidence method Rang of measurement: 44 to 83mm (both eyes), 22 to 41.5mm (each eye): Graduations:0.5mm. Range of focusing point:30 to infinity

瞳距仪
PD Meter

CP-32A1



CP-32AT



CP-32BT



CP-32B1



CP-32C1



CP-32C2



镜盒
CASES

4 - 21

清洗液
SPRAY

22 - 24

镜布
MICROFIBER

25 - 31

纸袋
BAGS

32 - 33

设备
EQUIPMENT

35 - 65

设备配件
EQUIPMENT ACCESSORIES

66 - 94

钳子
PLIERS

95 - 102

螺丝
SCREWS

103 - 105

眼镜配件
GLASSES ACCESSORIES

106 - 121

镜绳
GLASSES CHAINS

122 - 126

道具
PROPERTY

128 - 137

镜架
FRAME

139 - 146

镜片
LENS

148 - 153

礼品
GIFTS

155 - 157

镜盒
CASES
4-21
清洗液
SPRAY
22-24
镜布
MICROFIBER
25-31
纸袋
BAGS
32-33

设备
EQUIPMENT

35-65

设备配件
EQUIPMENT
ACCESSORIES

66-94

钳子
PLIERS

95-102

螺丝
SCREWS

103-105

眼镜配件
GLASSES
ACCESSORIES

106-121

镜绳
GLASSES
CHAINS

122-126

道具
PROPERTY

128-137

镜架
FRAME

139-146

镜片
LENS

148-153

礼品
GIFTS

155-157

CP-2A



CP-2B



CP-2C



FEATURES

Dimensions(L×W×H)	150×120×300mm
Weight	4kg
Power Requirement	110v/220v 60hz/50hz AC60W

Ideal for drilling holes in glass and plastic lenses. Opposing taper drill bits system allow holes to be drilled from both sides simultaneously for precised place and avoids chipping and breaking of all enses, especially those made of glass. After hole drilled, placle the lens under reamer and lifted upwards to be enlarge to desired size.

打孔机
Drilling apparatus

CP-10A



CP-10B



CP-10C



眼镜样板打孔机
Pattern drilling Machine



Tainless steel spare gasket. If its is very thin to the gasket in the all-rameglasses, it canbe added with stainless steel gasket in order to prevent form asket deformation.

FEATURES

Dimensions(L×W×H)	220×150×360mm/220×145×360mm
Weight	3kg
Power Requirement	110v/220v 60hz/50hz

It is an indispensable machine to fully automatic edger can replace for die plate in using in the edger it saves the trouble of opening the mould, it is practical, convenient and labor-saving it is yourideal choice.

打孔锯槽机
Lens Drilling & Slotting Machine

CP-24A



CP-24B



CP-24C



Add railing



Add light

FEATURES

Dimensions(L×W×H)	260×220×350mm
Weight	3kg
Power Requirement	110V/220V 60hz/50hz A250W

This machine is multi-functional special-purpose equipment for perforating and grooving of rimless frame It is most applicable to CR lens and PC lens to perforate and groove Opposing taper drill bits system allow holes to bedrilled simutanuously avoids chipping and breaking of all lenses, especially those made of glass. After hole drilled, placed the lens under reamer and lifted upwards to be enlarged to desired size the adjustable groove-cutting device can get accurate depth of groove cutting.

FEATURES

Dimensions(LxWxH)	215x122x44mm
Weight	0.2kg
Power Requirement	23A 12V battery DC5W

It owns precise optical structure,clear optical lineand precise measurement.Digital display for measurement result and separtely values displayed for left and right eyes.Easy operation and quick speed of measuring.It owns the auto power off and memory function after finishing the measuring which could save the electricity and keep the data welltican also be used in monocular the left eye and right eye separately.

数显瞳距尺
Digital PD Ruler

CP-30



查片仪
Hand Lens Meter

CP-1B



瞳高仪
PH Meter



CP-9B

瞳距瞳高仪
PD & PH Meter



CP-9

FEATURES

First, put the equipment on the glasses frame, and align the equipment center point to the frames bridge center. There has a rotary switch, can be twisted to adjust the pupil height measuring piece. And use the upperedge to aim at the pupil center. Then read the pupil height value at the lower edge of the frame.
PD Pupil height machine is invented with foreign advanced technology innovation.Which is convenient, intuitive, accurate and easy to use, etc. It is an integral tool of the multifocal progressive lens fitting.

FEATURES

Dimensions(LxWxH)	300x170x70mm
Weight	1kg
Power Requirement	110v/220v 60hz/50hz AC30W

Exquisite exterior shape.Advanced mechanical features.AC DC dual-purpose power source,it is portable to test in hand or on desk at anytime or any place.

LED中心仪
LED Centering Machine

FEATURES

Dimensions(LxWxH)	180x265x305mm
Weight	5.0kg
Power Requirement	110v/220v 60hz/50hz AC10W

Compact and pretty appearance design No vision difference on the display screen.no deformation and accurate lens layout obtained,Compensating the accuracy of the lens and suction cup position Bifocal lens can be positioned quickly and accurately,The small lens can also be put in clear projection.



CP-5D



CP-5DT

开模机
Pattern Maker

PM-400AT



FEATURES

Dimensions(LxWxH)	340x210x190mm
Weight	4kg
Power Requirement	110v/220v 60hz/50hz AC100W

Being based on the patterned lens or one lens from your eyeglasses to make the stardard pattern.It is easy and convenient to use clamping device equipped with three cupula bases according to different lens edgers and easy operation quick speed of cutting and high accuracy.

快速割片机
Lens Cutter

CP-4A



FEATURES

Put a lens which has been markde the axis on lens mete and layout blocker into the position of lens and then fix it by the left knob andbe ready to cut.Quick speed of cutter. Imported milling cut. With a knob to control the size of lens to cut.

镜盒
CASES

4 - 21

清洗液
SPRAY

22 - 24

镜布
MICROFIBER

25 - 31

纸袋
BAGS

32 - 33

设备
EQUIPMENT

35 - 65

设备配件
EQUIPMENT
ACCESSORIES

66 - 94

钳子
PLIERS

95 - 102

螺丝
SCREWS

103 - 105

眼镜配件
GLASSES
ACCESSORIES

106 - 121

镜绳
GLASSES
CHAINS

122 - 126

道具
PROPERTY

128 - 137

镜架
FRAME

139 - 146

镜片
LENS

148 - 153

礼品
GIFTS

155 - 157

- 镜盒
CASES
- 4 - 21
- 清洗液
SPRAY
- 22 - 24
- 镜布
MICROFIBER
- 25 - 31
- 纸袋
BAGS
- 32 - 33
- 设备
EQUIPMENT
- 35 - 65
- 设备配件
EQUIPMENT
ACCESSORIES
- 66 - 94
- 钳子
PLIERS
- 95 - 102
- 螺丝
SCREWS
- 103 - 105
- 眼镜配件
GLASSES
ACCESSORIES
- 106 - 121
- 镜绳
GLASSES
CHAINS
- 122 - 126
- 道具
PROPERTY
- 128 - 137
- 镜架
FRAME
- 139 - 146
- 镜片
LENS
- 148 - 153
- 礼品
GIFTS
- 155 - 157

CP-3T



CP-3CR



CP-3PCG



CP-3-800



FEATURES

Adjustable groove depth	form 0 to 0.7mm
Groove width	0.65mm
Lens thickness	from 1.5 to 11 mm
Lens	from 18 to 7mm
Dimensions(LxWxH)	210x170x150mm

Weight	2.7kg
Power Requirement	10v/220v 60hz/50hz AC60W
Product characteristics non corrosive machine body suitable for plastic and glass lenses.adjustable groove position(front-central-rear) no water system require accurate on all profiles.	



Internal Structure

开槽机
Lens Groover

CP-25



CP-26A



倒角机
Pattern drilling Machine

FEATURES

Dimensions(LxWxH)	170x210x150mm/270x230x210mm
Weight	2.7kg
Power Requirement	110v/220v 60hz/50hz
Lens evenly bevell Each side of lens are bevelled into same size. Simple and easy to operate.	

FEATURES

Dimensions(LxWxH)	340x140x250mm
Weight	10kg
Power Requirement	110v/220v 60hz/50hz AC110W
Multi-functional and easy operation right to groove, left to bevel.	

CP-6A



CP-6B



FEATURES

Dimensions(LxWxH)	395x245x295mm
Weight	9kg
Power Requirement	110v/220v 60hz/50hz AC120W
High speed rotating 3wheels operating getherjough-jinezgroove grinding with a special lamp convenient operating.	

手磨机
Hand Edger



20



35w



35wv

手磨机
Hand Edger

CP-7-20



CP-7-35W(CP-7-35WV)



FEATURES

Product Size	280×170×225mm
Grinding Wheel Size	14×100×20mm
Grinding Wheel Material	diamond
Grinding Wheel Rotation Speed	4200r/min
Voltage	AC220V/50Hz
Weight	3.8kg
Materials May Be Grinding	Resin, glass, PC, stone, cutting tool

FEATURES

Product Size	285×170×225mm
Grinding Wheel Size	14×100×35mm
Grinding Wheel Material	diamond
Grinding Wheel Rotation Speed	5500-6000r/min
Voltage	AC220V/50Hz
Weight	5kg
Grinding Wheel Parameters	35 wv type 16 mm width 35 mm right coarse grinding fine grinding 19 mm with V slot
Materials May Be Grinding	Resin, glass, PC, stone, cutting tool

CP-7A-20

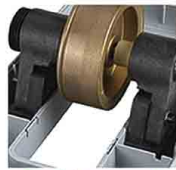

Double support

CP-7A-35W(CP-7A-35WV)

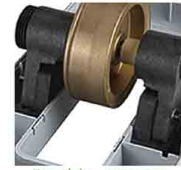

Double support

FEATURES

Product Size	350×220×280mm
Grinding Wheel Size	14×100×35mm
Grinding Wheel Material	diamond
Grinding Wheel Rotation Speed	4200r/min
Voltage	AC220V/50Hz
Weight	7.3kg
Grinding Wheel Parameters	35 w with V groove / 35 wv without V groove
Materials May Be Grinding	Resin, glass, PC, stone, cutting tool

CP-7B-20



CP-7B-35W(CP-7B-35WV)



Ventilation and heat dissipation

CP-11A-20



CP-11A-35W(CP-11A-35WV)



FEATURES

Product Size	360×225×303mm
Grinding Wheel Size	14×100×35mm
Grinding Wheel Material	diamond
Grinding Wheel Rotation Speed	4200r/min
Voltage	AC220V/50Hz
Weight	7.3kg
Grinding Wheel Parameters	35 w with V groove / 35 wv without V groove
Materials May Be Grinding	Resin, glass, PC, stone, cutting tool

镜盒
CASES

4 - 21

清洗液
SPRAY

22 - 24

镜布
MICROFIBER

25 - 31

纸袋
BAGS

32 - 33

设备
EQUIPMENT

35 - 65

设备配件
EQUIPMENT

ACCESSORIES

66 - 94

钳子
PLIERS

95 - 102

螺丝
SCREWS

103 - 105

眼镜配件
GLASSES

ACCESSORIES

106 - 121

镜绳
GLASSES

CHAINS

122 - 126

道具
PROPERTY

128 - 137

镜架
FRAME

139 - 146

镜片
LENS

148 - 153

礼品
GIFTS

155 - 157

镜盒
CASES

4 - 21

清洗液
SPRAY

22 - 24

镜布
MICROFIBER

25 - 31

纸袋
BAGS

32 - 33

设备
EQUIPMENT

35 - 65

设备配件
EQUIPMENT
ACCESSORIES

66 - 94

钳子
PLIERS

95 - 102

螺丝
SCREWS

103 - 105

眼镜配件
GLASSES
ACCESSORIES

106 - 121

镜绳
GLASSES
CHAINS

122 - 126

道具
PROPERTY

128 - 137

镜架
FRAME

139 - 146

镜片
LENS

148 - 153

礼品
GIFTS

155 - 157

手磨机
Hand Edger

CP-20A



FEATURES

Dimensions(LxWxH)	440x320x300mm/570x465x430mm
Weight	15kg
Power Requirement	110v/220v 60hz/50hz

Big power,high speed rotation,quick speed of grinding the lens.



抛光机
Multifunction Polisher

CP-36



FEATURES

Packing Dimension	340x490x360mm
G.W	9.4kg
Packing Quantity	2pcs/ctn
Carton Size	510x710x390mm
Approx G.W	20.7kg



FEATURES

Dimensions(LxWxH)	395x245x300mm
Weight	8kg
Power Requirement	110v/220v 60hz/50hz Ac100W

big power,high speed rotation and quick grinding With rough
、 fine- groove & widen 35mm grinding wheel and polishing
wheel.

CP-8

CP-8B

CP-8A



FEATURES

Dimensions(LxWxH)	214x270x240mm/330x280x320mm
Weight	7.6kg
Power Requirement	110v/220v 60hz/50hz

Aclear machine hood allows for constant inspection of the lens polishing to reduces nois and aids dust absorbing.

FEATURES

Dimensions(LxWxH)	450x230x250mm/430x230x260mm
Weight	5kg
Power Requirement	110v/220v 60hz/50hz

This feature is the largest of two different speed,suitable for polishing CR lenses and PC lens,and av oid the PC olishing lenses in the process of deformation.

镜架加热器
Frame Heater

FEATURES

Dimensions(LxWxH)	200x150x270mm/195x150x270mm
Weight	1kg
Power Requirement	110v/220v 60hz/50hz /A515W
500W Power of heating coil	500W
5W Power of motor	15W
15W Power of motor	15W
1.8m/s Wind speed	1.8m/s
80°C-130°C Temperature Setting	80°C-130°C



FEATURES

Dimensions(LxWxH)	305x145x190mm
Weight	1.2kg
Power Requirement	110v/220v 60hz/50hz /A515W
Wind Speed	1.8m/s
Temperature Setting	80°C-130°C
Packing Quantity	10pacs/ctn
Carton Size	360x440x740mm
Approx G.W	13kg



FEATURES

Power	110VAC 1500W Fuse:15A
	220VAC 1500W Fuse:10A
Low Temperature	80 C -100 C
Ambient Temperature	25 C
High Temperature	130 C -170 C
Ambient Temperature	25 C
Size	305x210x220mm(LxWxH)
Weight	3kg

FEATURES

Power	110VAC 1500W Fuse:15A
	220VAC 1500W Fuse:10A
Low Temperature	80 C -100 C
Ambient Temperature	25 C
High Temperature	130 C -170 C
Ambient Temperature	25 C
Size	305x210x220mm(LxWxH)
Weight	3kg



螺钉起拔器

Screw Extractor



FEATURES

Dimensions(LxWxH)	100x85x70mm
Weight	0.5kg

For taking out the broken screws in the frame Equipped with the shanks and easy operation.



UV-400 调节旋钮
UV 400 Knob

FEATURES

Dimensions(LxWxH)	273x162x112mm
Weight	5kg
Power Requirement	110v/220v 60hz/50hz AC20W

It is the most convenient and practical UV-400 measuring instrument. It isobviously to read the values of the anti-uv.

UV-400测试仪
UV-400 Tester

多功能镜片测试仪

Multifunctional Lens Tester



FEATURES

Stress testing
Multi-focal lens testing
Lens scratches check

镜盒
CASES

4 - 21

清洗液
SPRAY

22 - 24

镜布
MICROFIBER

25 - 31

纸袋
BAGS

32 - 33

设备
EQUIPMENT

35 - 65

设备配件
EQUIPMENT
ACCESSORIES

66 - 94

钳子
PLIERS

95 - 102

螺丝
SCREWS

103 - 105

眼镜配件
GLASSES
ACCESSORIES

106 - 121

镜绳
GLASSES
CHAINS

122 - 126

道具
PROPERTY

128 - 137

镜架
FRAME

139 - 146

镜片
LENS

148 - 153

礼品
GIFTS

155 - 157

镜盒
CASES

4 - 21

清洗液
SPRAY

22 - 24

镜布
MICROFIBER

25 - 31

纸袋
BAGS

32 - 33

设备
EQUIPMENT

35 - 65

设备配件
EQUIPMENT
ACCESSORIES

66 - 94

钳子
PLIERS

95 - 102

螺丝
SCREWS

103 - 105

眼镜配件
GLASSES
ACCESSORIES

106 - 121

镜绳
GLASSES
CHAINS

122 - 126

道具
PROPERTY

128 - 137

镜架
FRAME

139 - 146

镜片
LENS

148 - 153

礼品
GIFTS

155 - 157

防蓝光测试仪 UV+420 Cut Demonstrstration Tool

RLT828



FEATURES

How to turn on the lights
The kit uses AA batteriesX8
Open the battery box and place the batteries please ensure that +/- is correct
Make sure that the switch of the battery box is on
Please press the main power switch
The kit can run continuously for up to 10 hours so when the liqhe brightness starts to decrease please change the 8 batteries at that time
The kit can be used with the provided AC adapter of DC 12V

镜片变色测试仪 Photochromic Lens Tester

CP-14



FEATURES

Dimensions(LxWxH) 220x110x115mm
Weight 0.3kg
Power Requirement 110v/220v 60hz/50hz AC30W
It will be your good choice to test the photochromic lens in short time by the flash light.

CP-14A



FEATURES

Dimensions(LxWxH) 205x127x93mm
Weight 219g
Power Requirement 110v/220v 60hz/50hz AC30W
It will be your good choice to test the photochromic lens in short time by the flash light.

升降台 Ectrick Work Table

LY-3A



CP-31A



CP-31AT



精品轮
Fine wheel



好轮
Good wheel



普通轮
Common wheel

FEATURES

Dimensions(LxWxH) 610x530x265mm
Weight 19kg
Power Requirement 110v/220v 60hz/50hz AC120W
Electric V L580mmxW400mm/L480mmxW400mm
range for up and down 630mm-820mm
Range of elevation 630mm-820mm
Max loading 50kg-75kg

Electric Work Table is made of imported materials and absorb the fo reign advanced technology. Featuring with fine appearance, safety andcredibility of operation system Its load capacity can reach 75kgs at most It is easy and convenient to move the table, low noise, stable and large

CP-31ADT



染色机
Dying Machine

FEATURES

Size (LxWxH)	490x290x190mm
Temperature	0 C~100 C
Cup Volume	1000ML
Power	1500W
Power requirement	220V/50HZ110V/60HZ



CT-51001-3

FEATURES

Size (LxWxH)	490x290x190mm
Temperature	0 C~100 C
Cup Volume	1000ML
Power	3000W
Power requirement	220V/50HZ110V/60HZ



CT-51001-4

染色夹
Staining Rack



RM-1



RM-2



RM-3



CT-51001-5

FEATURES

Size (LxWxH)	390x300x190mm
Temperature	0 C~100 C
Cup Volume	700ML
Power	1500W
Power requirement	220V/50HZ110V/60HZ

数控钻孔机
Digital Drilling Machine

FEATURES

The operation procedures are highly intelligent and totally digital Compared to the hole position of the pattern lensjt has higher process accuracyWhose process deviation is less than0.075mm in both X-axis and Y-axis. It has auto position clamping equipment which allows to remain the same process accuracy after the change of clamps.The screen shows the drill position and coordinates data, and gives guidance to the operation The hole position memory function allows to process the set hole positions continuously. Original pattern measurement mode and mirroring function measurement mode.The head can automatically reposition if it's removed from itsposition accidentallyThe instrument drills automatically in a set order, and can be corrected by pressing the number.



CP-2M

视力仪灯箱
Visual Chart



FEATURES

LEDMultifunctional LED	920mmx280mmx25mm
Power Requirement	220V±22V、50Hz ± 1Hz -
LED rating Life	5000h

(5m Standard logarithm) Vision Table Light Box outline dimensions
Light temperature not less than 6500K
Uniform coefficient not less than 0.7

CB-34

镜盒
CASES

4 - 21

清洗液
SPRAY

22 - 24

镜布
MICROFIBER

25 - 31

纸袋
BAGS

32 - 33

设备
EQUIPMENT

35 - 65

设备配件
EQUIPMENT
ACCESSORIES

66 - 94

钳子
FILERS

95 - 102

螺丝
SCREWS

103 - 105

眼镜配件
GLASSES
ACCESSORIES

106 - 121

镜绳
GLASSES
CHAINS

122 - 126

道具
PROPERTY

128 - 137

镜架
FRAME

139 - 146

镜片
LENS

148 - 153

礼品
GIFTS

155 - 157

- 镜盒
CASES
- 4-21
- 清洗液
SPRAY
- 22-24
- 镜布
MICROFIBER
- 25-31
- 纸袋
BAGS
- 32-33
- 设备
EQUIPMENT
- 35-65
- 设备配件
EQUIPMENT
ACCESSORIES
- 66-94
- 钳子
PLIERS
- 95-102
- 螺丝
SCREWS
- 103-105
- 眼镜配件
GLASSES
ACCESSORIES
- 106-121
- 镜绳
GLASSES
CHAINS
- 122-126
- 道具
PROPERTY
- 128-137
- 镜架
FRAME
- 139-146
- 镜片
LENS
- 148-153
- 礼品
GIFTS
- 155-157

CB-006/CB030

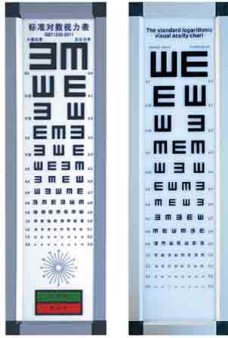

FEATURES

LED Multifunctional LED 920mm×280mm×25mm
Power Requirement 220V±22V、50Hz ± 1Hz -
LED rating Life 5000h
(5m Standard logarithm) Vision Table Light Box outline dimensions
Light temperature not less than 6500K
0.7Uniform coefficient not less than 0.7

CB-008



FEATURES

LED Multifunctional LED 920mm×450mm×25mm
Power Requirement 220V±22V、50Hz ± 1Hz -
LED rating Life 5000h
(5m Standard logarithm) Vision Table Light Box outline dimensions
Light temperature not less than 6500K
0.7Uniform coefficient not less than 0.7

CB-010



FEATURES

LED Multifunctional LED 620mm×280mm×25mm
Power Requirement 220V±22V、50Hz ± 1Hz -
LED rating Life 5000h
(5m Standard logarithm) Vision Table Light Box outline dimensions
Light temperature not less than 6500K
0.7Uniform coefficient not less than 0.7

CB-020



FEATURES

LED Multifunctional LED 920mm×280mm×25mm
Power Requirement 220V±22V、50Hz ± 1Hz -
LED rating Life 5000h
(5m Standard logarithm) Vision Table Light Box outline dimensions
Light temperature not less than 6500K
0.7Uniform coefficient not less than 0.7

CB-021



FEATURES

LED Multifunctional LED 620mm×280mm×25mm
Power Requirement 220V±22V、50Hz ± 1Hz -
LED rating Life 5000h
(2.5m Standard logarithm) Vision Table Light Box outline dimensions
Light temperature not less than 6500K
0.7Uniform coefficient not less than 0.7

CB-022

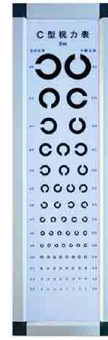

FEATURES

LED Multifunctional LED 920mm×280mm×25mm
Power Requirement 220V±22V、50Hz ± 1Hz -
LED rating Life 5000h
(5m Standard logarithm) Vision Table Light Box outline dimensions
Light temperature not less than 6500K
0.7Uniform coefficient not less than 0.7

CB-031



FEATURES

LED Multifunctional LED 920mm×280mm×25mm
Power Requirement 220V±22V、50Hz ± 1Hz -
LED rating Life 5000h
(5m Standard logarithm) Vision Table Light Box outline dimensions
Light temperature not less than 6500K
Uniform coefficient not less than 0.7

CB-032



FEATURES

LED Multifunctional LED 920mm×280mm×25mm
Power Requirement 220V±22V、50Hz ± 1Hz -
LED rating Life 5000h
Light temperature not less than 6500K
Uniform coefficient not less than 0.7

CB-033



FEATURES

LED Multifunctional LED 620mm×280mm×25mm
Power Requirement 220V±22V、50Hz ± 1Hz -
LED rating Life 5000h
(5m Standard logarithm) Vision Table Light Box outline dimensions
Light temperature not less than 6500K
Uniform coefficient not less than 0.7

RUC-1



FEATURES

Outside size(LxWxH)	27x17x24cm
Inside groove(LxWxH)	24x14x10cm
Volume	3000ML
Temperature	20°C~80°C
Ultrasonic power	100W
Power requirement	AC100-120V 60HZ AC200-240V 50HZ

RUC-2



FEATURES

Outside size(LxWxH)	19x17x18.5cm
Inside groove(LxWxH)	15x14x6.5cm
Volume	1300ML
Ultrasonic power	50W
Power requirement	AC100-120V 60HZ AC200-240V 50HZ

RUC-4



FEATURES

Outside size(LxWxH)	23x18x16cm
Inside groove(LxWxH)	17.5x14.5x7cm
Volume	1300ML
Ultrasonic power	60W
Power requirement	AC100-120V 60HZ AC200-240V 50HZ

RUC-5



FEATURES

Outside size(LxWxH)	30.5x23.5x21.5cm
Inside groove(LxWxH)	24.5x15.5x8cm
Volume	2500ML
Ultrasonic power	50W
Power requirement	AC100-120V 60HZ AC200-240V 50HZ

RUC-6



FEATURES

Outside size(LxWxH)	20x14x12.5cm
Inside groove(LxWxH)	15.5x9.5x5.2cm
Volume	600ML
Ultrasonic power	35W
Power requirement	AC100-120V 60HZ AC200-240V 50HZ

RUC-7



FEATURES

Outside size(LxWxH)	20x14x12.5cm
Inside groove(LxWxH)	15.5x9.5x5.2cm
Volume	600ML
Ultrasonic power	35W
Power requirement	AC100-120V 60HZ AC200-240V 50HZ

RUC-8



FEATURES

Outside size(LxWxH)	9.9x18.8x5.8cm
Inside groove(LxWxH)	9.2x18.5x4.8cm
Volume	450ML
Ultrasonic power	15W
Power requirement	AC100-120V 60HZ AC200-240V 50HZ

RUC-11



FEATURES

Outside size(LxWxH)	31.4x24.3x20.4cm
Inside groove(LxWxH)	24.5x15.0x7.6cm
Volume	2500ml
Ultrasonic	170W

RUC-12



FEATURES

Outside size(LxWxH)	38.5x23.4x19.3cm
Inside groove(LxWxH)	25.0x17.4x7.8cm
Volume	3000ml
Ultrasonic	150W

镜盒
CASES

4 - 21

清洗液
SPRAY

22 - 24

镜布
MICROFIBER

25 - 31

纸袋
BAGS

32 - 33

设备
EQUIPMENT

35 - 65

设备配件
EQUIPMENT
ACCESSORIES

66 - 94

钳子
FILERS

95 - 102

螺丝
SCREWS

103 - 105

眼镜配件
GLASSES
ACCESSORIES

106 - 121

镜绳
GLASSES
CHAINS

122 - 126

道具
PROPERTY

128 - 137

镜架
FRAME

139 - 146

镜片
LENS

148 - 153

礼品
GIFTS

155 - 157

- 镜盒
CASES
- 4-21
- 清洗液
SPRAY
- 22-24
- 镜布
MICROFIBER
- 25-31
- 纸袋
BAGS
- 32-33
- 设备
EQUIPMENT
- 35-65
- 设备配件
EQUIPMENT
ACCESSORIES
- 66-94
- 钳子
PLIERS
- 95-102
- 螺丝
SCREWS
- 103-105
- 眼镜配件
GLASSES
ACCESSORIES
- 106-121
- 镜绳
GLASSES
CHAINS
- 122-126
- 道具
PROPERTY
- 128-137
- 镜架
FRAME
- 139-146
- 镜片
LENS
- 148-153
- 礼品
GIFTS
- 155-157



Sample Product No. 样品产品规则:

JSC-266P-A

Number of piece	Trial Lens Material	Set Material
104 pcs	-Metal	A -Silver Aluminum Case ✓
158 pcs	P -Plastic ✓	B -Black Aluminum Case
232 pcs		X -Leather Case
266 pcs ✓		

Number of piece & Trial lens material 圈数&圈材质:



JSC-104-A Metal金属



JSC-104P-A Plastic塑料



JSC-158-A Metal金属



JSC-158P-A Plastic塑料

FEATURES

Spheres	10.0 8.00 7.00 6.00 5.00 4.50 4.00 3.50 3.00 2.50 2.00 1.75 1.50 1.25 1.00 0.75 0.50 0.25	four pcs each
Cylinders	3.00 2.00 1.00 0.75 0.50 0.25	four pcs each
Prisms	0.5 1.0	two pcs each
Accessories	FL SS PH BL	one pcs each

Spheres(+)		Spheres(-)				Cylinders(+)		Cylinders(-)		Prisms		Accessories			
degree	pcs	degree	pcs	degree	pcs	degree	pcs	degree	pcs	degree	pcs	degree	pcs		
0.25	2	3.00	2	0.25	2	3.00	2	0.25	2	0.25	2	0.5△	1	B1	1
0.50	2	3.50	2	0.50	2	3.50	2	0.50	2	0.50	2	1.0△	1	RF	1
0.75	2	4.00	2	0.75	2	4.00	2	0.75	2	0.75	2	2.0△	1	PL	1
1.00	2	4.50	2	1.00	2	4.50	2	1.00	2	1.00	2	3.0△	1	Crosscylinder	1
1.25	2	5.00	2	1.25	2	5.00	2	2.00	2	2.00	2				
1.50	2	6.00	2	1.50	2	6.00	2	3.00	2	3.00	2				
1.75	2	7.00	2	1.75	2	7.00	2								
2.00	2	8.00	2	2.00	2	8.00	2								
2.50	2	10.00	2	2.50	2	10.00	2								

FEATURES

Spheres	25 pairs each of concave and convex 0.25D to 4.00D in 0.25 steps 4.50D 5.00D to 12.00 in 1.00
Cylinders	12 pairs each of concave and convex 0.25D to 2.00D in 0.25 steps 2.50D to 4.00D in 0.50 steps
Prisms	4 pieces 0.5 1.0 2.0 3.0
Accessories	6pieces RF BL CL PH SS Crosscylinder

Spheres(+)		Spheres(-)				Cylinders(+)		Cylinders(-)		Prisms		Accessories			
degree	pcs	degree	pcs	degree	pcs	degree	pcs	degree	pcs	degree	pcs	degree	pcs		
0.25	2	3.50	2	0.25	2	3.50	2	0.25	2	0.25	2	0.5△	1	B1	1
0.50	2	3.75	2	0.50	2	3.75	2	0.50	2	0.50	2	1.0△	1	RF	1
0.75	2	4.00	2	0.75	2	4.00	2	0.75	2	0.75	2	2.0△	1	PH1.5	1
1.00	2	4.50	2	1.00	2	4.50	2	1.00	2	1.00	2	3.0△	1	SS1.5	1
1.25	2	5.00	2	1.25	2	5.00	2	1.25	2	1.25	2			PL	1
1.50	2	5.50	2	1.50	2	5.50	2	1.50	2	1.50	2			Crosscylinder	1
1.75	2	6.00	2	1.75	2	6.00	2	1.75	2	1.75	2				
2.00	2	7.00	2	2.00	2	7.00	2	2.00	2	2.00	2				
2.25	2	8.00	2	2.25	2	8.00	2	2.50	2	2.50	2				
2.50	2	9.00	2	2.50	2	9.00	2	3.00	2	3.00	2				
2.75	2	10.00	2	2.75	2	10.00	2	3.50	2	3.50	2				
3.00	2	12.00	2	3.00	2	12.00	2	4.00	2	4.00	2				
3.25	2			3.25	2										



JSC-232-A Metal金属



JSC-232P-A Plastic塑料

FEATURES

Spheres 35 pairs each of concave and convex 0.12D 0.25 D to 4.00D in 0.25 steps 4.50D to 7.50D in 0.50 steps
8.00D to 15.00 in 1.00 steps 16.00D to 20.00D in 2.00 steps
Cylinders 17 pairs each of concave and convex 0.12D 0.25D to 2.25D in 0.25 steps 2.50D to 4.50D in 0.50 steps
5.00D to 6.00D in 1.00 steps
Prisms 12 pieces 0.5 1.0 2.0 3.0 4.0 5.0 6.0 8.0 10.0
Accessories 12 pieces RF GF BL PL MR FL CL PH SS PF Crosscylinder x0.25x0.50

Spheres(+)		Spheres(-)				Cylinders(+)		Cylinders(-)		Prisms		Accessories			
degree	pcs	degree	pcs	degree	pcs	degree	pcs	degree	pcs	degree	pcs	degree	pcs		
0.12	2	5.00	2	0.12	2	5.00	2	0.12	2	0.12	2	0.5△	2	B1	1
0.25	2	5.50	2	0.25	2	5.50	2	0.25	2	0.25	2	1.0△	2	PH1.5	1
0.50	2	6.00	2	0.50	2	6.00	2	0.50	2	0.50	2	2.0△	2	SS1.5	1
0.75	2	6.50	2	0.75	2	6.50	2	0.75	2	0.75	2	3.0△	1	GF	1
1.00	2	7.00	2	1.00	2	7.00	2	1.00	2	1.00	2	4.0△	1	RF	1
1.25	2	7.50	2	1.25	2	7.50	2	1.25	2	1.25	2	5.0△	1	MR	1
1.50	2	8.00	2	1.50	2	8.00	2	1.50	2	1.50	2	6.0△	1	PL	1
1.75	2	8.50	2	1.75	2	8.50	2	1.75	2	1.75	2	7.0△	1	FL	2
2.00	2	9.00	2	2.00	2	9.00	2	2.00	2	2.00	2	8.0△	1	CL	2
2.25	2	10.00	2	2.25	2	10.00	2	2.25	2	2.25	2			Crosscylinder	1
2.50	2	11.00	2	2.50	2	11.00	2	2.50	2	2.50	2				
2.75	2	12.00	2	2.75	2	12.00	2	2.75	2	2.75	2				
3.00	2	13.00	2	3.00	2	13.00	2	3.00	2	3.00	2				
3.25	2	14.00	2	3.25	2	14.00	2	3.25	2	3.25	2				
3.50	2	16.00	2	3.50	2	16.00	2	3.50	2	3.50	2				
3.75	2	18.00	2	3.75	2	18.00	2	3.75	2	3.75	2				
4.00	2	20.00	2	4.00	2	20.00	2	4.00	2	4.00	2				
4.50	2			4.50	2										

FEATURES

Spheres 40 pairs each of concave and convex 0.25D to 6.00D in 0.25 steps 6.50D to 10.00D in 0.50 steps
11.00D to 15.00 in 1.00 steps 16.00D to 20.00D in 2.00 steps
Cylinders 20 pairs each of concave and convex 0.25D to 4.00D in 0.25 steps 4.50D to 6.00D in 0.50 steps
Prisms 12 pieces 0.5 1.0 to 10.0 in 1.0 steps
Accessories 14 pieces RF GF BL PL MR FL CL PH SS PF Crosscylinder x0.25 x0.50

Spheres(+)		Spheres(-)				Cylinders(+)		Cylinders(-)		Prisms		Accessories			
degree	pcs	degree	pcs	degree	pcs	degree	pcs	degree	pcs	degree	pcs	degree	pcs		
0.12	2	5.00	2	0.12	2	5.00	2	0.12	2	0.12	2	0.5△	2	B1	1
0.25	2	5.25	2	0.25	2	5.25	2	0.25	2	0.25	2	1.0△	2	PH1.5	1
0.50	2	5.50	2	0.50	2	5.50	2	0.50	2	0.50	2	2.0△	2	SS1.5	1
0.75	2	5.75	2	0.75	2	5.75	2	0.75	2	0.75	2	3.0△	1	GF	1
1.00	2	6.00	2	1.00	2	6.00	2	1.00	2	1.00	2	4.0△	1	RF	1
1.25	2	6.50	2	1.25	2	6.50	2	1.25	2	1.25	2	5.0△	1	MR	1
1.50	2	7.00	2	1.50	2	7.00	2	1.50	2	1.50	2	6.0△	1	PL	1
1.75	2	7.50	2	1.75	2	7.50	2	1.75	2	1.75	2	7.0△	1	FL	2
2.00	2	8.00	2	2.00	2	8.00	2	2.00	2	2.00	2	8.0△	1	CL	2
2.25	2	8.50	2	2.25	2	8.50	2	2.25	2	2.25	2			Crosscylinder	2
2.50	2	9.00	2	2.50	2	9.00	2	2.50	2	2.50	2				
2.75	2	9.50	2	2.75	2	9.50	2	2.75	2	2.75	2				
3.00	2	10.00	2	3.00	2	10.00	2	3.00	2	3.00	2				
3.25	2	11.00	2	3.25	2	11.00	2	3.25	2	3.25	2				
3.50	2	12.00	2	3.50	2	12.00	2	3.50	2	3.50	2				
3.75	2	13.00	2	3.75	2	13.00	2	3.75	2	3.75	2				
4.00	2	14.00	2	4.00	2	14.00	2	4.00	2	4.00	2				
4.25	2	16.00	2	4.25	2	16.00	2	4.50	2	4.50	2				
4.50	2	18.00	2	4.50	2	18.00	2	5.00	2	5.00	2				
4.75	2	20.00	2	4.75	2	20.00	2	6.00	2	6.00	2				



JSC-266-A Metal金属



JSC-266P-A Plastic塑料

Sets material 外箱材质:



A

Silver Aluminum Case / 银色铝箱



B

Black Aluminum Case / 黑色铝箱



X

Leather Case 皮箱

- 镜盒 CASES 4-21
- 清洗液 SPRAY 22-24
- 镜布 MICROFIBER 25-31
- 纸袋 BAGS 32-33
- 设备 EQUIPMENT 35-65
- 设备配件 EQUIPMENT ACCESSORIES 66-94
- 钳子 PLIERS 95-102
- 螺丝 SCREWS 103-105
- 眼镜配件 GLASSES ACCESSORIES 106-121
- 镜绳 GLASSES CHAINS 122-126
- 道具 PROPERTY 128-137
- 镜架 FRAME 139-146
- 镜片 LENS 148-153
- 礼品 GIFTS 155-157

- 镜盒
CASES
- 4 - 21
- 清洗液
SPRAY
- 22 - 24
- 镜布
MICROFIBER
- 25 - 31
- 纸袋
BAGS
- 32 - 33
- 设备
EQUIPMENT
- 35 - 65
- 设备配件
EQUIPMENT ACCESSORIES
- 66 - 94
- 钳子
PLIERS
- 95 - 102
- 螺丝
SCREWS
- 103 - 105
- 眼镜配件
GLASSES ACCESSORIES
- 106 - 121
- 镜绳
GLASSES CHAINS
- 122 - 126
- 道具
PROPERTY
- 128 - 137
- 镜架
FRAME
- 139 - 146
- 镜片
LENS
- 148 - 153
- 礼品
GIFTS
- 155 - 157



JSC-18L

FEATURES

Progressive Lenses Sphere 9 pairs each of concave and convex 1.00D to 3.00D in 0.25 steps



Progressive	
degree	pcs
+1.00	2
+1.25	2
+1.50	2
+1.75	2
+2.00	2
+2.25	2
+2.50	2
+2.75	2
+3.00	2



Progressive trial lens



JSC-18P

FEATURES

5 pairs of progressive refractors: pd58 ~ pd66, increasing every 2mm
Incremental tablets group 9: add + 1.00 ~ add + 3.00, increasing every + 0.25
A piece of insert movable turning mirror
A pen lamp
A shortsighted card

Trial Frame		Progressive		Accessories	
degree	pcs	degree	pcs	degree	pcs
PD58	1	+1.00	2	Pen Lamp	1
PD60	1	+1.25	2	Adjustable Flippers	1
PD62	1	+1.50	2	Visual Card	1
PD64	1	+1.75	2		
PD66	1	+2.00	2		
		+2.25	2		
		+2.50	2		
		+2.75	2		
		+3.00	2		

INSTRUCTIONS

1. Adjust the distant pupil distance
2. Standard vision (including allophtic vision and subjective vision, binocular balance)
3. Add determination: the patient put on the correction lens, and then did the add examination.
Add = (age - 30) × 0.1
4. Comparison with proximity mirror
Insert a set of add + 2.00d progressive film on one side of the insert movable turnover mirror, and place + 2.00d in front of the corrected eyes for far, middle and near.
The patient reflected that: they can only see near, but can not see far clearly; the swing reverse mirror is replaced by add + 2.00, and the patient can see far, middle and near, and the object can be seen clearly by changing different examples.
5. Try on
According to the measurement of add, a pair of progressive test pieces were taken and put into the trial wearing frame with remote light. They were asked to read books, read computers, and walk to try them on.

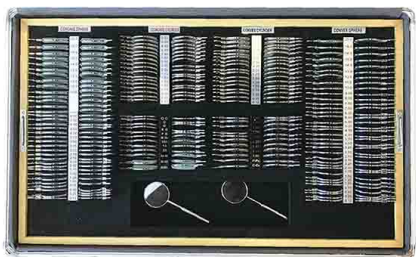

JSC-256

FEATURES

Spheres 35 pairs each of concave and convex 0.12D 0.25 D to 4.00D in 0.25 steps 4.50D to 7.50D in 0.50 steps 8.00D to 15.00 in 1.00 steps 16.00D to 20.00D in 2.00 steps
Cylinders 17 pairs each of concave and convex 0.25D to 3.00D in 0.25 steps 3.50D to 4.00D in 0.50 steps
Prisms 12 pieces 0.5 1.0 to 8.0 in 1.0 steps
Accessories 11 pieces B1 PH SS GF RF MR PL FL CL Crosscylinder

Spheres(+)		Spheres(-)				Cylinders(+)		Cylinders(-)		Prisms		Accessories			
degree	pcs	degree	pcs	degree	pcs	degree	pcs	degree	pcs	degree	pcs	degree	pcs		
0.12	2	6.00	2	0.12	2	6.00	2	0.12	2	0.12	2	0.5△	2	B1	1
0.25	2	6.50	2	0.25	2	6.50	2	0.25	2	0.25	2	1.0△	2	PH1.5	1
0.50	2	7.00	2	0.50	2	7.00	2	0.50	2	0.50	2	2.0△	2	SS1.5	1
0.75	2	7.50	2	0.75	2	7.50	2	0.75	2	0.75	2	3.0△	1	GF	1
1.00	2	8.00	2	1.00	2	8.00	2	1.00	2	1.00	2	4.0△	1	RF	1
1.25	2	9.00	2	1.25	2	9.00	2	1.25	2	1.25	2	5.0△	1	MR	1
1.50	2	9.50	2	1.50	2	9.50	2	1.50	2	1.50	2	6.0△	1	PL	1
1.75	2	10.00	2	1.75	2	10.00	2	1.75	2	1.75	2	7.0△	1	FL	2
2.00	2	11.00	2	2.00	2	11.00	2	2.00	2	2.00	2	8.0△	1	CL	2
2.25	2	12.00	2	2.25	2	12.00	2	2.25	2	2.25	2			Crossed cylindrical	2
2.50	2	13.00	2	2.50	2	13.00	2	2.50	2	2.50	2			Progressive	
2.75	2	14.00	2	2.75	2	14.00	2	2.75	2	2.75	2			+1.00	2
3.00	2	16.00	2	3.00	2	16.00	2	3.00	2	3.00	2			+1.25	2
3.25	2	18.00	2	3.25	2	18.00	2	3.50	2	3.50	2			+1.50	2
3.50	2	20.00	2	3.50	2	20.00	2	4.00	2	4.00	2			+1.75	2
3.75	2			3.75	2			5.00	2	5.00	2			+2.00	2
4.00	2			4.00	2			6.00	2	6.00	2			+2.25	2
4.50	2			4.50	2									+2.50	2
5.00	2			5.00	2									+2.75	2
5.50	2			5.50	2									+3.00	2



验光架-CDE尺寸 CDE SIZE: 48 50 52 54 56 58 60 62 64 66 68 70 72



排镜
Board Lenses

三棱镜
Triangular Prism

块状棱镜
Lump Prism



度数 degrees
±25
±50
±100
±150
±200
±250
±300
±350
±400
度数可定制

可调翻转拍
AdjustableFlippers

可调翻转拍
AdjustableFlippers

翻转拍
Flippers

翻转拍
Flippers

OA058 OA058-1
2030视力卡 2040视力卡
vision card



试镜片
Trial Clip

排镜
Board Lenses

交叉圆柱镜
Cross Cylinder
25° / 50°

镜盒 CASES	4 - 21
清洗液 SPRAY	22 - 24
镜布 MICROFIBER	25 - 31
纸袋 BAGS	32 - 33
设备 EQUIPMENT	35 - 65
设备配件 EQUIPMENT ACCESSORIES	66 - 94
钳子 PLIERS	95 - 102
螺丝 SCREWS	103 - 105
眼镜配件 GLASSES ACCESSORIES	106 - 121
镜绳 GLASSES CHAINS	122 - 126
道具 PROPERTY	128 - 137
镜架 FRAME	139 - 146
镜片 LENS	148 - 153
礼品 GIFTS	155 - 157